



DUAL 6kW DOL SEWERAGE PUMP STATION CONTROL



Automation Group's Baker Switchboards division has been manufacturing premium switchboards for over 60 years. The Dual 6kW DOL sewerage pump station control is a sewerage pump starter with 2 pumps that are controlled by a multitrode level controller. It has the option to run 1 pump at a time or 2 pumps with one being backup for high pumping requirements. The board is pre-wired for supply authority metering to be fitted.

PRODUCT HIGHLIGHTS

- Completely wired ready for use, quick install time
- Separate sections for metering, control and power
- IP66 for outdoor use
- Ease of connection for supply Authority metering
- Battery backup for communication



FEATURES

- Full automated or manual control system
- Local indication for pump status - Volts, Amps, run, fault, hours run
- External strobe alarms for high level
- Compatible with multiple RTU/radio and SCADA platforms for flexibility ease of install
- Electronic overloads for motor protection
- Uses Multitrode controllers for level with back up float system

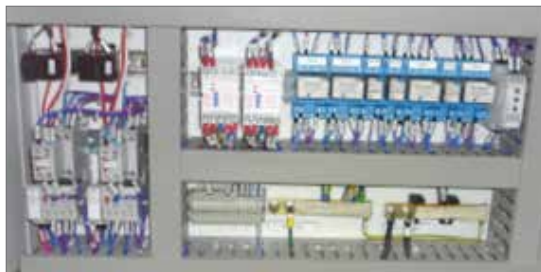

APPLICATION

Specifically designed for DOL dual sewerage pumping



TECHNICAL SPECIFICATIONS

GENERAL

Supply	415VAC
Control	24VDC
Real Time Clock	Internal - Year, month, date, hour, minute, second Automatic DNP3 time synchronisation from host
Motor Protection	Electronic Overload Trip Class 10
Current	<100A

CERTIFICATIONS AND COMPLIANCE

AS/NZS3000:2007	Wiring rules electrical installations
AS/NZ3439.1	Low voltage Switchgear and control gear assemblies
NSW service and Installation Rules	Whole current metering

MECHANICAL SPECIFICATIONS

Dimensions	200 x 600 x 400mm
Weight	240kg
Mounting	Floor Mounted
Material	Powder Coated Pebble Grey (RAL7032) 1.6mm steel AL & S/S options

Other variations of this product available upon request

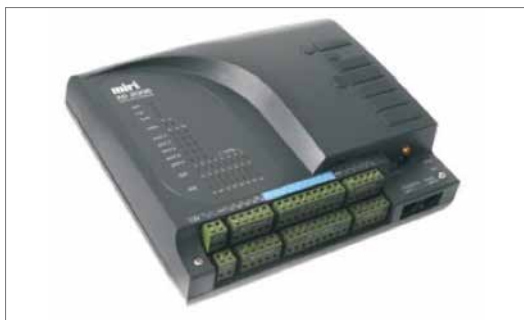
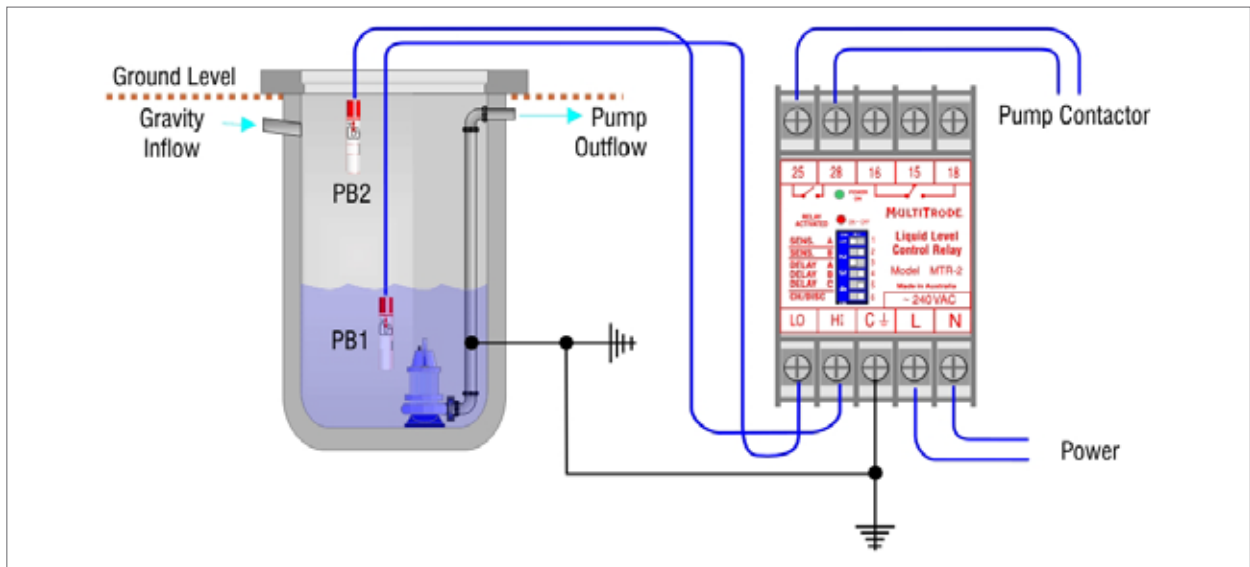

QUALITY, SAFETY & INDUSTRY STANDARDS

Baker Switchboards is committed to quality, safety and adhering to the highest industry standards. As part of our commitment we ensure that our systems meet or exceed the ISO 9001 and AS 4801 industry standards. These are externally audited by SGS Australia to ensure our systems are in accordance with the standards.



Automation Group

Sydney • Newcastle • Dubbo • Brisbane • Melbourne • Perth

P 1300 724 743 E sales@automationgroup.com.au W automationgroup.com.au

Baker Switchboards Sales

P 02 6884 0488 • F 02 6884 0489