



DISCRETE TRANSMITTER SM5010-DS1 / SM5010-DJ1



PRODUCT HIGHLIGHTS

- High Performance WIO® Wireless Connectivity
- Ideal Solution for Dry Contact Switches and Monitoring Alarm Conditions
- Wirelessly Monitor On/Off Status
- Provides 2 Inputs for Dry Contact Relay or Open-Drain Output Devices
- Seamless Integration with Third-Party Devices
- Direct or Pipe-mounting Versions for Integration Flexibility
- License-Free 900 MHz Band, Secure Data Transmission (2.4 GHz Optional)
- Intrinsically Safe for Use in Hazardous Locations
- Self-Contained Battery Operation
- Easy-to-Install, Configure and Use
- User-Friendly BreeZ® Configuration Software

WIRELESS SENSOR NETWORK

- Reliable, Robust Wireless Performance
- Eliminates Costly Conduits and Wiring
- Monitor/Control Process Conditions 24/7
- License-Free ISM Band, FSK & FHSS Technologies
- Reduces Labour, Installation and Maintenance Costs
- Meet Regulatory Requirements
- Industrial Strength Performance & Durability

Wireless Discrete Monitoring	2 Discrete Inputs	Multi -Vendor Compatible
Direct or Pipe - Mount Version	Exception Reporting Device	915-928 MHz ISM License-Free Band
Self-Contained Battery Operation	Up to 10-year Battery Life	Class I; Division 1

APPLICATIONS

- Oil & Gas, Pipeline, Petro-Chem, Water/Wastewater, Utilities, Irrigation Systems, Mining, SCADA Systems, On/Off Status, 3A Sanitary, Pharmaceuticals, Biotechnology, and Much More



TECHNICAL SPECIFICATIONS



HARDWARE FEATURES

Device Functionality	Discrete Input Monitor w/ Built-In Wireless Transmitter
Embedded Controller	Ultra-low Power RISC Microcontroller with Internal FLASH (Field Upgradeable)
I/O Interface	Up to 2 Inputs for Dry Contact Relay or Open-drain Output Devices
User Interface	Standard RS232 Serial
Power Source	Self-Contained, Internal 3.6 V Lithium Battery
Internal Battery Life	Up to 10 Years, Based on Usage
Self-Diagnostics	Contains Comprehensive Self-Checking Software and Hardware for Continuous Monitoring of Operation

WIRELESS COMMUNICATIONS

Type: 900MHz	ISM Band, FSK (Frequency-Shift Keying), FHSS (Frequency Hopping Spread Spectrum)
Frequency	915 MHz to 928 MHz
Data Rate	115.2 kbps / 9600 bps
Output Power	1 mW to 10 mW
Receiving Sensitivity	-100 dBm @ 115.2 bps or -110 dBm @ 9600 bps
Range	Up to 2.3km with Clear Line of Sight
Type: 2.4GHz	Optional Version Available, ISM Band, DSSS

CERTIFICATIONS

FCC	FCC Part 15
Australia	
Industry Canada	(IC) ICES-003
Safety	  Intrinsically Safe for Use in Hazardous Environments Class I; Division 1, Group A, B, C & D T3C Class I; Zone 0 Ex ia IIC T3 / Class I; Zone 0, AEx ia IIC T3

MECHANICAL SPECIFICATIONS

Transmitter Dimensions	127 mm (W) x 325 mm (H) x 108 mm (D)
Mounting Hardware	Direct or Pipe Mount
Hardware Connection	W/O Junction Box: 19mm NPT Male; W/ Junction Box: 19mm NPT Female
Enclosure Casing Material	Type 4X Aluminum; IP66

ELECTRICAL SPECIFICATIONS

DC Power Input	30 VDC Maximum; 12 VDC Normal; 9 VDC Minimum
Average Power Input	2 Watt
Power Consumption	Idle: 100 mA; Configuration: 110 mA; Transmission: 350mA

GENERAL SPECIFICATIONS

Operating Conditions	Ambient Temperature (Class I; Division 1): -40°C to 70°C Ambient Temperature (Non-Hazardous Applications): -40°C to 85°C
Humidity:	0 to 99%, Non-Condensing
Warranty	2-Year Parts and Labour

ORDERING INFORMATION

This Device is	Discrete Transmitter SM5010-DS1 / SM5010-DJ1w/ Junction Box
Wirelessly Connects to	WIO® Gateways: Base Unit or DH2



BASIC NETWORKING DIAGRAM

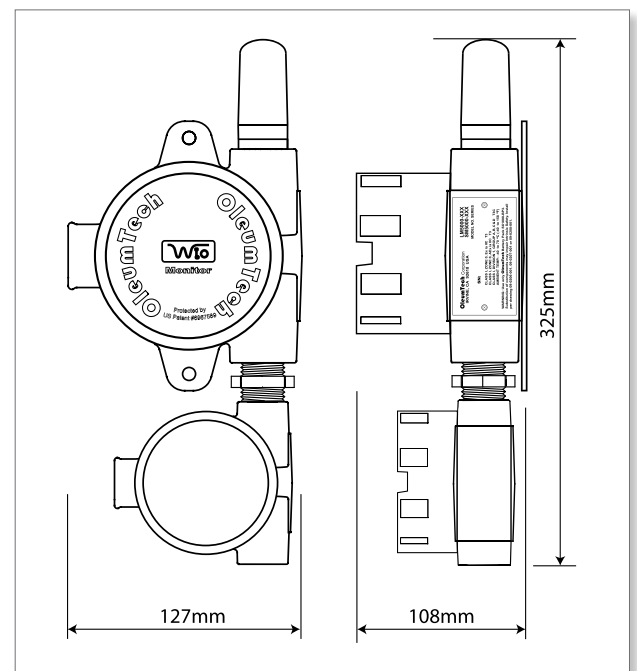

Automation Group

Sydney • Newcastle • Dubbo • Brisbane • Melbourne • Perth

P 1300 724 743 E sales@automationgroup.com.au W automationgroup.com.au